

# ISMB 600

Indian Standard Medium Weight Beam — IS 808 : 1989

CROSS SECTION (Proportionally Accurate — True Radii)

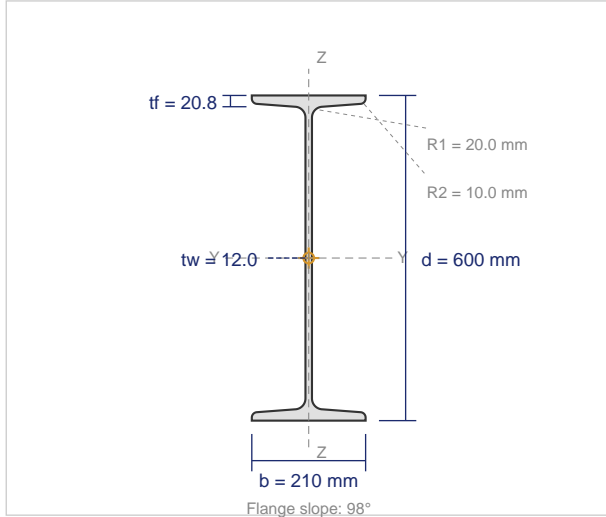

## DIMENSIONS

Depth (d)	600 mm
Flange Width (b)	210 mm
Web Thickness (tw)	12.0 mm
Flange Thickness (tf)	20.8 mm
Root Radius (R1)	20.0 mm
Toe Radius (R2)	10.0 mm
Flange Slope	98°
Weight per Meter	122.6 kg/m
Cross-sectional Area	15620 mm <sup>2</sup>

## SECTIONAL PROPERTIES

Property	About X-X Axis	About Y-Y Axis
Moment of Inertia	<b>I<sub>x</sub> = 918130000 mm<sup>4</sup></b>	<b>I<sub>y</sub> = 26490000 mm<sup>4</sup></b>
Elastic Section Modulus	<b>Z<sub>x</sub> = 3060400 mm<sup>3</sup></b>	<b>Z<sub>y</sub> = 252300 mm<sup>3</sup></b>
Plastic Section Modulus	<b>Z<sub>px</sub> = 3555000 mm<sup>3</sup></b>	<b>Z<sub>py</sub> = 397400 mm<sup>3</sup></b>
Radius of Gyration	<b>r<sub>x</sub> = 242.4 mm</b>	<b>r<sub>y</sub> = 41.2 mm</b>
Torsional Constant	<b>I<sub>t</sub> = 975000 mm<sup>4</sup></b>	
Warping Constant	<b>I<sub>w</sub> = 181000000000 mm<sup>6</sup></b>	

## AVAILABLE GRADES (IS 2062 : 2011)

Grade	Yield (MPa)	UTS (MPa)	Elongation	Application
E250 (Fe 410W)	250	410	23%	General construction
E275 (Fe 440)	275	440	22%	Commercial buildings
E300	300	440	22%	Industrial structures
E350 (Fe 490)	350	490	22%	Heavy industrial, bridges
E410 (Fe 540)	410	540	20%	Heavy structural, offshore
E450 (Fe 570)	450	570	20%	Bridges, towers

## APPLICABLE STANDARDS

<b>IS 808 : 1989</b>	Dimensions for hot rolled steel beam, column, channel and angle sections
<b>IS 2062 : 2011</b>	Hot rolled medium and high tensile structural steel
<b>IS 1852</b>	Tolerances for hot rolled structural steel sections