

ISMB 550

Indian Standard Medium Weight Beam — IS 808 : 1989

CROSS SECTION (Proportionally Accurate — True Radii)

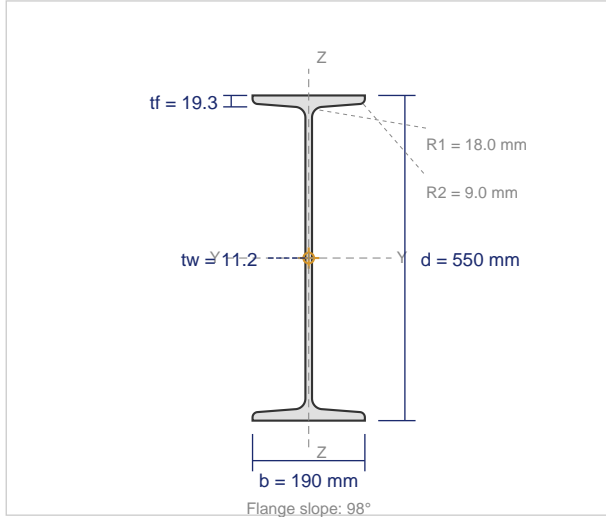

DIMENSIONS

Depth (d)	550 mm
Flange Width (b)	190 mm
Web Thickness (tw)	11.2 mm
Flange Thickness (tf)	19.3 mm
Root Radius (R1)	18.0 mm
Toe Radius (R2)	9.0 mm
Flange Slope	98°
Weight per Meter	103.7 kg/m
Cross-sectional Area	13210 mm ²

SECTIONAL PROPERTIES

Property	About X-X Axis	About Y-Y Axis
Moment of Inertia	I_x = 648930000 mm⁴	I_y = 18340000 mm⁴
Elastic Section Modulus	Z_x = 2359700 mm³	Z_y = 193100 mm³
Plastic Section Modulus	Z_{px} = 2738000 mm³	Z_{py} = 304400 mm³
Radius of Gyration	r_x = 221.6 mm	r_y = 37.3 mm
Torsional Constant	I_t = 771000 mm⁴	
Warping Constant	I_w = 1140000000000 mm⁶	

AVAILABLE GRADES (IS 2062 : 2011)

Grade	Yield (MPa)	UTS (MPa)	Elongation	Application
E250 (Fe 410W)	250	410	23%	General construction
E275 (Fe 440)	275	440	22%	Commercial buildings
E300	300	440	22%	Industrial structures
E350 (Fe 490)	350	490	22%	Heavy industrial, bridges
E410 (Fe 540)	410	540	20%	Heavy structural, offshore
E450 (Fe 570)	450	570	20%	Bridges, towers

APPLICABLE STANDARDS

IS 808 : 1989	Dimensions for hot rolled steel beam, column, channel and angle sections
IS 2062 : 2011	Hot rolled medium and high tensile structural steel
IS 1852	Tolerances for hot rolled structural steel sections