

ISMB 500

Indian Standard Medium Weight Beam — IS 808 : 1989

CROSS SECTION (Proportionally Accurate — True Radii)

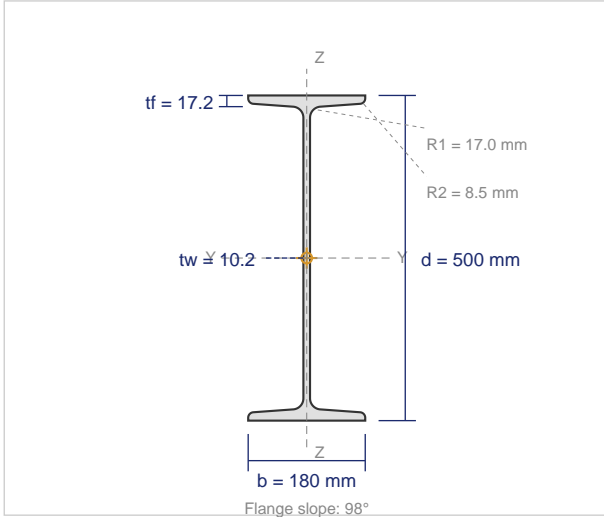

DIMENSIONS

Depth (d)	500 mm
Flange Width (b)	180 mm
Web Thickness (tw)	10.2 mm
Flange Thickness (tf)	17.2 mm
Root Radius (R1)	17.0 mm
Toe Radius (R2)	8.5 mm
Flange Slope	98°
Weight per Meter	86.9 kg/m
Cross-sectional Area	11070 mm ²

SECTIONAL PROPERTIES

Property	About X-X Axis	About Y-Y Axis
Moment of Inertia	I_x = 452180000 mm⁴	I_y = 13700000 mm⁴
Elastic Section Modulus	Z_x = 1808700 mm³	Z_y = 152200 mm³
Plastic Section Modulus	Z_{px} = 2091000 mm³	Z_{py} = 239600 mm³
Radius of Gyration	r_x = 202.1 mm	r_y = 35.2 mm
Torsional Constant	I_t = 556000 mm⁴	
Warping Constant	I_w = 75200000000 mm⁶	

AVAILABLE GRADES (IS 2062 : 2011)

Grade	Yield (MPa)	UTS (MPa)	Elongation	Application
E250 (Fe 410W)	250	410	23%	General construction
E275 (Fe 440)	275	440	22%	Commercial buildings
E300	300	440	22%	Industrial structures
E350 (Fe 490)	350	490	22%	Heavy industrial, bridges
E410 (Fe 540)	410	540	20%	Heavy structural, offshore
E450 (Fe 570)	450	570	20%	Bridges, towers

APPLICABLE STANDARDS

IS 808 : 1989	Dimensions for hot rolled steel beam, column, channel and angle sections
IS 2062 : 2011	Hot rolled medium and high tensile structural steel
IS 1852	Tolerances for hot rolled structural steel sections