

ISMB 200

Indian Standard Medium Weight Beam — IS 808 : 1989

CROSS SECTION (Proportionally Accurate — True Radii)

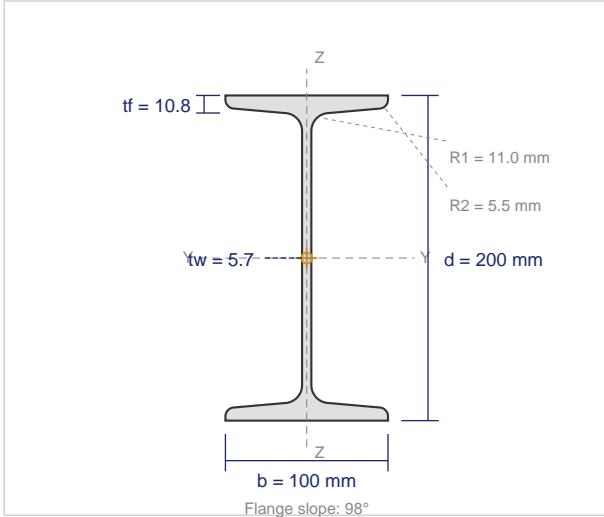

DIMENSIONS

Depth (d)	200 mm
Flange Width (b)	100 mm
Web Thickness (tw)	5.7 mm
Flange Thickness (tf)	10.8 mm
Root Radius (R1)	11.0 mm
Toe Radius (R2)	5.5 mm
Flange Slope	98°
Weight per Meter	25.4 kg/m
Cross-sectional Area	3230 mm ²

SECTIONAL PROPERTIES

Property	About X-X Axis	About Y-Y Axis
Moment of Inertia	$I_x = 22350000 \text{ mm}^4$	$I_y = 1500000 \text{ mm}^4$
Elastic Section Modulus	$Z_x = 223500 \text{ mm}^3$	$Z_y = 30000 \text{ mm}^3$
Plastic Section Modulus	$Z_{px} = 258400 \text{ mm}^3$	$Z_{py} = 47400 \text{ mm}^3$
Radius of Gyration	$r_x = 83.2 \text{ mm}$	$r_y = 21.5 \text{ mm}$
Torsional Constant	$I_t = 125000 \text{ mm}^4$	
Warping Constant	$I_w = 22500000000 \text{ mm}^6$	

AVAILABLE GRADES (IS 2062 : 2011)

Grade	Yield (MPa)	UTS (MPa)	Elongation	Application
E250 (Fe 410W)	250	410	23%	General construction
E275 (Fe 440)	275	440	22%	Commercial buildings
E300	300	440	22%	Industrial structures
E350 (Fe 490)	350	490	22%	Heavy industrial, bridges
E410 (Fe 540)	410	540	20%	Heavy structural, offshore
E450 (Fe 570)	450	570	20%	Bridges, towers

APPLICABLE STANDARDS

IS 808 : 1989	Dimensions for hot rolled steel beam, column, channel and angle sections
IS 2062 : 2011	Hot rolled medium and high tensile structural steel
IS 1852	Tolerances for hot rolled structural steel sections