

ISHB 450 SH

Indian Standard Heavy Beam -- IS 808 : 1989

CROSS SECTION (Proportionally Accurate)

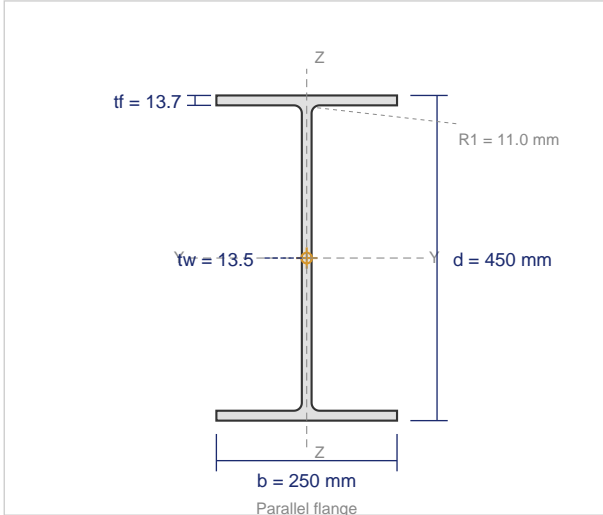

DIMENSIONS

Depth (d)	450 mm
Flange Width (b)	250 mm
Web Thickness (tw)	13.5 mm
Flange Thickness (tf)	13.7 mm
Root Radius (R1)	11.0 mm
Variant	Super Heavy
Weight per Meter	92.5 kg/m
Cross-sectional Area	11789 mm ²
Surface Area	1.826 m ² /m

SECTIONAL PROPERTIES

Property	About X-X Axis	About Y-Y Axis
Moment of Inertia	I_x = 337,067,000 mm⁴	I_y = 36,104,000 mm⁴
Elastic Section Modulus	Z_x = 1,498,100 mm³	Z_y = 288,800 mm³
Plastic Section Modulus	Z_{px} = 1,718,300 mm³	Z_{py} = 442,000 mm³
Radius of Gyration	r_x = 169.1 mm	r_y = 55.3 mm
Distance to Extreme Fibre	c_x = 225.0 mm	c_y = 125.0 mm
Shape Factor (Z _p /Z)	1.147	1.530
Torsional Constant	I_t = 827,800 mm⁴	
Warping Constant	I_w = 1,748,500,000,000 mm⁶	
Shear Area	A_v = 6,075 mm²	

FACTORED CAPACITY (per IS 800:2007, gamma_m0 = 1.10)

Grade	Mp X-X (kN.m)	Mp Y-Y (kN.m)	Axial Pd (kN)
E 250 (Fe 410W)	390.5	100.5	2679
E 350	546.7	140.6	3751
E 410	640.5	164.7	4394
E 450	702.9	180.8	4823

APPLICABLE STANDARDS

IS 808 : 1989	Dimensions for hot rolled steel beam, column, channel and angle sections
IS 2062 : 2011	Hot rolled medium and high tensile structural steel
IS 800 : 2007	General construction in steel -- Code of practice
IS 1852	Tolerances for hot rolled structural steel sections