

ISHB 400 H

Indian Standard Heavy Beam -- IS 808 : 1989

CROSS SECTION (Proportionally Accurate)

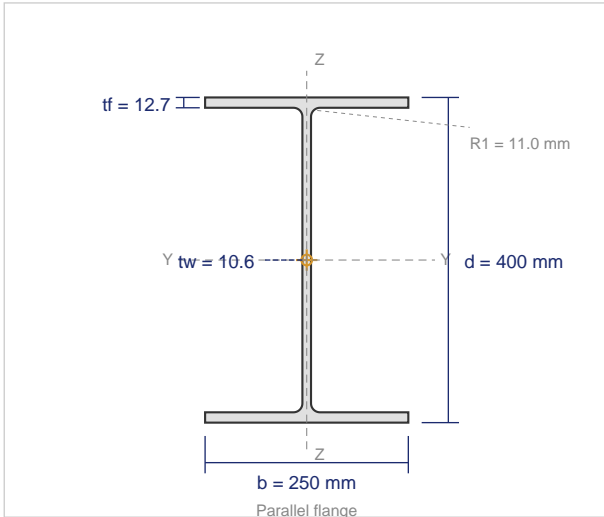

DIMENSIONS

Depth (d)	400 mm
Flange Width (b)	250 mm
Web Thickness (tw)	10.6 mm
Flange Thickness (tf)	12.7 mm
Root Radius (R1)	11.0 mm
Variant	Heavy
Weight per Meter	77.4 kg/m
Cross-sectional Area	9866 mm ²
Surface Area	1.730 m ² /m

SECTIONAL PROPERTIES

Property	About X-X Axis	About Y-Y Axis
Moment of Inertia	I_x = 245,712,000 mm⁴	I_y = 33,404,000 mm⁴
Elastic Section Modulus	Z_x = 1,228,600 mm³	Z_y = 267,200 mm³
Plastic Section Modulus	Z_{px} = 1,396,700 mm³	Z_{py} = 408,200 mm³
Radius of Gyration	r_x = 157.8 mm	r_y = 58.1 mm
Distance to Extreme Fibre	c_x = 200.0 mm	c_y = 125.0 mm
Shape Factor (Z _p /Z)	1.137	1.528
Torsional Constant	I_t = 586,100 mm⁴	
Warping Constant	I_w = 1,257,500,000,000 mm⁶	
Shear Area	A_v = 4,240 mm²	

FACTORED CAPACITY (per IS 800:2007, gamma_m0 = 1.10)

Grade	Mp X-X (kN.m)	Mp Y-Y (kN.m)	Axial Pd (kN)
E 250 (Fe 410W)	317.4	92.8	2242
E 350	444.4	129.9	3139
E 410	520.6	152.1	3677
E 450	571.4	167.0	4036

APPLICABLE STANDARDS

IS 808 : 1989	Dimensions for hot rolled steel beam, column, channel and angle sections
IS 2062 : 2011	Hot rolled medium and high tensile structural steel
IS 800 : 2007	General construction in steel -- Code of practice
IS 1852	Tolerances for hot rolled structural steel sections