

ISMC 400

Indian Standard Medium Weight Channel -- IS 808 : 1989

CROSS SECTION (Proportionally Accurate)

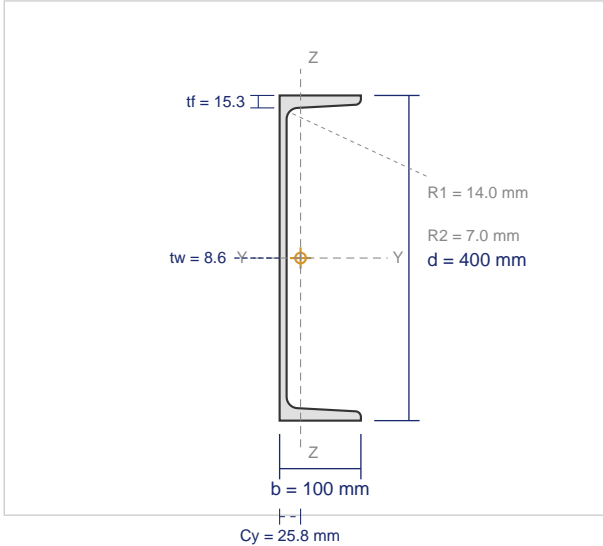

DIMENSIONS

Depth (d)	400 mm
Flange Width (b)	100 mm
Web Thickness (tw)	8.6 mm
Flange Thickness (tf)	15.3 mm
Root Radius (R1)	14.0 mm
Toe Radius (R2)	7.0 mm
Centroid (Cy)	25.8 mm
Weight per Meter	49.4 kg/m
Cross-sectional Area	6293 mm ²

SECTIONAL PROPERTIES

Property	About X-X Axis	About Y-Y Axis
Moment of Inertia	I_x = 150820000 mm⁴	I_y = 5048000 mm⁴
Elastic Section Modulus	Z_x = 754100 mm³	Z_y = 67200 mm³
Plastic Section Modulus	Z_{px} = 891200 mm³	Z_{py} = 117300 mm³
Radius of Gyration	r_x = 154.8 mm	r_y = 28.3 mm
Centroid from Web	C_y = 25.8 mm	
Torsional Constant	I_t = 295000 mm⁴	

AVAILABLE GRADES (IS 2062 : 2011)

Grade	Yield (MPa)	UTS (MPa)	Elongation	Application
E250 (Fe 410W)	250	410	23%	General construction
E275 (Fe 440)	275	440	22%	Commercial buildings
E300	300	440	22%	Industrial structures
E350 (Fe 490)	350	490	22%	Heavy industrial, bridges
E410 (Fe 540)	410	540	20%	Heavy structural, offshore
E450 (Fe 570)	450	570	20%	Bridges, towers

APPLICABLE STANDARDS

IS 808 : 1989	Dimensions for hot rolled steel beam, column, channel and angle sections
IS 2062 : 2011	Hot rolled medium and high tensile structural steel
IS 1852	Tolerances for hot rolled structural steel sections