

ISMC 300

Indian Standard Medium Weight Channel -- IS 808 : 1989

CROSS SECTION (Proportionally Accurate)

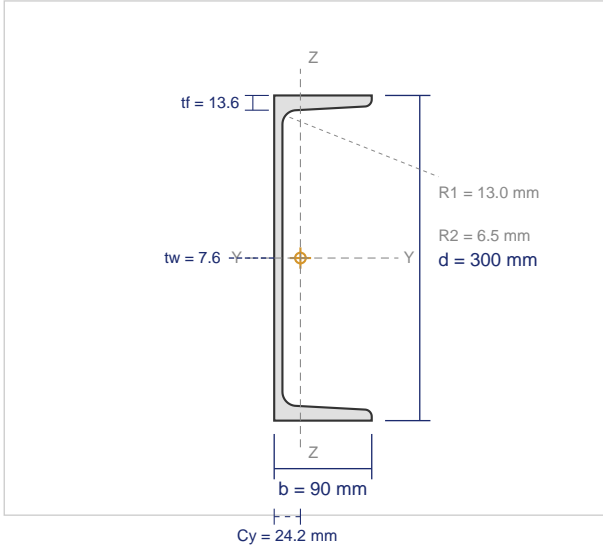

DIMENSIONS

Depth (d)	300 mm
Flange Width (b)	90 mm
Web Thickness (tw)	7.6 mm
Flange Thickness (tf)	13.6 mm
Root Radius (R1)	13.0 mm
Toe Radius (R2)	6.5 mm
Centroid (Cy)	24.2 mm
Weight per Meter	36.3 kg/m
Cross-sectional Area	4630 mm ²

SECTIONAL PROPERTIES

Property	About X-X Axis	About Y-Y Axis
Moment of Inertia	Ix = 63620000 mm⁴	Iy = 3100000 mm⁴
Elastic Section Modulus	Zx = 424200 mm³	Zy = 46300 mm³
Plastic Section Modulus	Zpx = 499300 mm³	Zpy = 80200 mm³
Radius of Gyration	rx = 117.2 mm	ry = 25.9 mm
Centroid from Web	Cy = 24.2 mm	
Torsional Constant	It = 205000 mm⁴	

AVAILABLE GRADES (IS 2062 : 2011)

Grade	Yield (MPa)	UTS (MPa)	Elongation	Application
E250 (Fe 410W)	250	410	23%	General construction
E275 (Fe 440)	275	440	22%	Commercial buildings
E300	300	440	22%	Industrial structures
E350 (Fe 490)	350	490	22%	Heavy industrial, bridges
E410 (Fe 540)	410	540	20%	Heavy structural, offshore
E450 (Fe 570)	450	570	20%	Bridges, towers

APPLICABLE STANDARDS

IS 808 : 1989	Dimensions for hot rolled steel beam, column, channel and angle sections
IS 2062 : 2011	Hot rolled medium and high tensile structural steel
IS 1852	Tolerances for hot rolled structural steel sections