

# ISMC 175

Indian Standard Medium Weight Channel -- IS 808 : 1989

## CROSS SECTION (Proportionally Accurate)

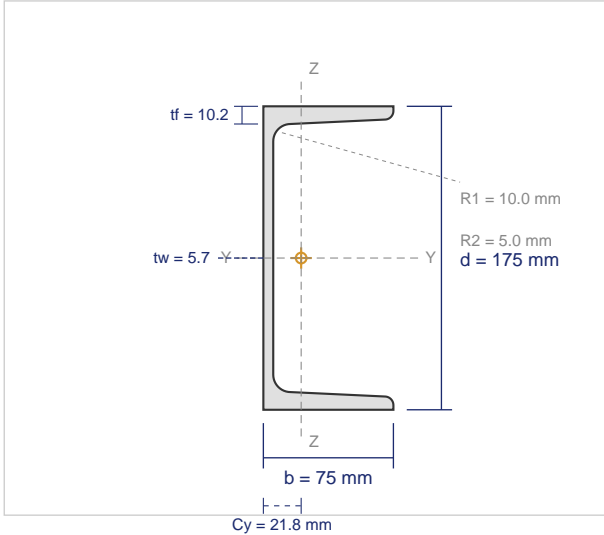

## DIMENSIONS

Depth (d)	175 mm
Flange Width (b)	75 mm
Web Thickness (tw)	5.7 mm
Flange Thickness (tf)	10.2 mm
Root Radius (R1)	10.0 mm
Toe Radius (R2)	5.0 mm
Centroid (Cy)	21.8 mm
Weight per Meter	19.1 kg/m
Cross-sectional Area	2438 mm <sup>2</sup>

## SECTIONAL PROPERTIES

Property	About X-X Axis	About Y-Y Axis
Moment of Inertia	<b>I<sub>x</sub> = 12230000 mm<sup>4</sup></b>	<b>I<sub>y</sub> = 1220000 mm<sup>4</sup></b>
Elastic Section Modulus	<b>Z<sub>x</sub> = 139800 mm<sup>3</sup></b>	<b>Z<sub>y</sub> = 22800 mm<sup>3</sup></b>
Plastic Section Modulus	<b>Z<sub>px</sub> = 164300 mm<sup>3</sup></b>	<b>Z<sub>py</sub> = 39200 mm<sup>3</sup></b>
Radius of Gyration	<b>r<sub>x</sub> = 70.8 mm</b>	<b>r<sub>y</sub> = 22.4 mm</b>
Centroid from Web	<b>C<sub>y</sub> = 21.8 mm</b>	
Torsional Constant	<b>I<sub>t</sub> = 87000 mm<sup>4</sup></b>	

## AVAILABLE GRADES (IS 2062 : 2011)

Grade	Yield (MPa)	UTS (MPa)	Elongation	Application
E250 (Fe 410W)	250	410	23%	General construction
E275 (Fe 440)	275	440	22%	Commercial buildings
E300	300	440	22%	Industrial structures
E350 (Fe 490)	350	490	22%	Heavy industrial, bridges
E410 (Fe 540)	410	540	20%	Heavy structural, offshore
E450 (Fe 570)	450	570	20%	Bridges, towers

## APPLICABLE STANDARDS

<b>IS 808 : 1989</b>	Dimensions for hot rolled steel beam, column, channel and angle sections
<b>IS 2062 : 2011</b>	Hot rolled medium and high tensile structural steel
<b>IS 1852</b>	Tolerances for hot rolled structural steel sections