

ISMC 125

Indian Standard Medium Weight Channel -- IS 808 : 1989

CROSS SECTION (Proportionally Accurate)

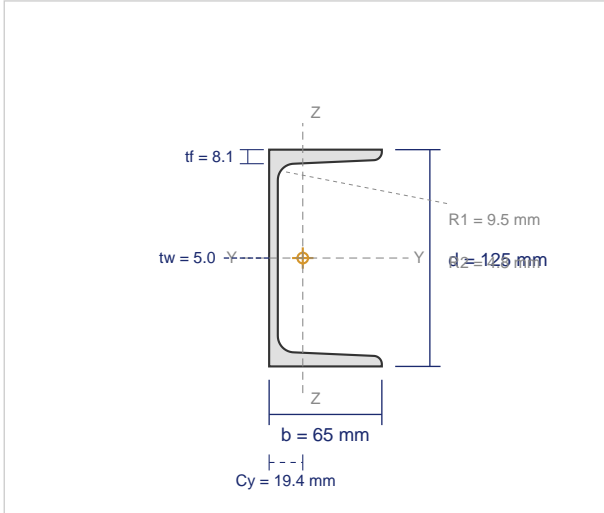

DIMENSIONS

Depth (d)	125 mm
Flange Width (b)	65 mm
Web Thickness (tw)	5.0 mm
Flange Thickness (tf)	8.1 mm
Root Radius (R1)	9.5 mm
Toe Radius (R2)	4.8 mm
Centroid (Cy)	19.4 mm
Weight per Meter	12.7 kg/m
Cross-sectional Area	1619 mm ²

SECTIONAL PROPERTIES

Property	About X-X Axis	About Y-Y Axis
Moment of Inertia	I_x = 4259000 mm⁴	I_y = 602000 mm⁴
Elastic Section Modulus	Z_x = 68100 mm³	Z_y = 13400 mm³
Plastic Section Modulus	Z_{px} = 79800 mm³	Z_{py} = 23000 mm³
Radius of Gyration	r_x = 51.3 mm	r_y = 19.3 mm
Centroid from Web	C_y = 19.4 mm	
Torsional Constant	I_t = 45000 mm⁴	

AVAILABLE GRADES (IS 2062 : 2011)

Grade	Yield (MPa)	UTS (MPa)	Elongation	Application
E250 (Fe 410W)	250	410	23%	General construction
E275 (Fe 440)	275	440	22%	Commercial buildings
E300	300	440	22%	Industrial structures
E350 (Fe 490)	350	490	22%	Heavy industrial, bridges
E410 (Fe 540)	410	540	20%	Heavy structural, offshore
E450 (Fe 570)	450	570	20%	Bridges, towers

APPLICABLE STANDARDS

IS 808 : 1989	Dimensions for hot rolled steel beam, column, channel and angle sections
IS 2062 : 2011	Hot rolled medium and high tensile structural steel
IS 1852	Tolerances for hot rolled structural steel sections