

ISA 100x100x10

Indian Standard Equal Leg Angle -- IS 808 : 1989

CROSS SECTION

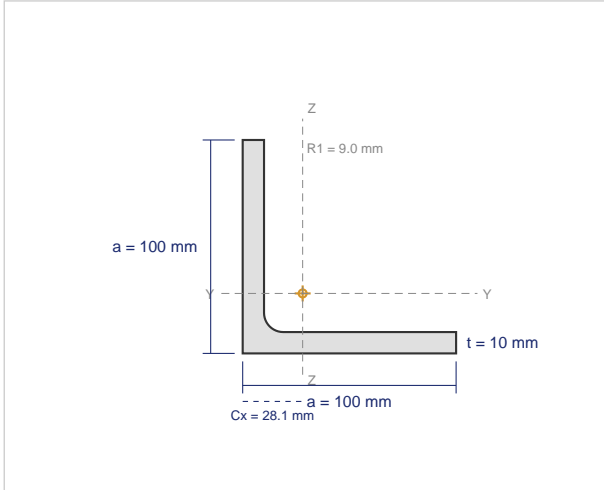

DIMENSIONS

| | |
|----------------------|----------------------|
| Leg A | 100 mm |
| Leg B | 100 mm |
| Thickness (t) | 10 mm |
| Root Radius (R1) | 9.0 mm |
| Toe Radius (R2) | 4.5 mm |
| Centroid Cx | 28.1 mm |
| Centroid Cy | 28.1 mm |
| Weight per Meter | 14.9 kg/m |
| Cross-sectional Area | 1900 mm ² |

SECTIONAL PROPERTIES

| Property | About X-X Axis | About Y-Y Axis |
|-------------------------|------------------------------------|------------------------------------|
| Moment of Inertia | Ix = 1270000 mm⁴ | Iy = 1270000 mm⁴ |
| Elastic Section Modulus | Zx = 18200 mm³ | Zy = 18200 mm³ |
| Radius of Gyration | rx = 25.9 mm | ry = 25.9 mm |
| Centroid from Heel | Cx = 28.1 mm | Cy = 28.1 mm |

AVAILABLE GRADES (IS 2062 : 2011)

| Grade | Yield (MPa) | UTS (MPa) | Elongation | Application |
|----------------|-------------|-----------|------------|----------------------------|
| E250 (Fe 410W) | 250 | 410 | 23% | General construction |
| E275 (Fe 440) | 275 | 440 | 22% | Commercial buildings |
| E350 (Fe 490) | 350 | 490 | 22% | Heavy industrial, bridges |
| E410 (Fe 540) | 410 | 540 | 20% | Heavy structural, offshore |

APPLICABLE STANDARDS

| | |
|-----------------------|--|
| IS 808 : 1989 | Dimensions for hot rolled steel beam, column, channel and angle sections |
| IS 2062 : 2011 | Hot rolled medium and high tensile structural steel |
| IS 1852 | Tolerances for hot rolled structural steel sections |